

Parent Pointers

Calendar

Sunday	Monday	Tuesday	Wednesday	Thursday	Friday	Saturday
		1 Collect photos and memorabilia from your teen's high school years. They make a treasured graduation gift.	2 Encourage your teen to create some school year resolutions. Write them down and put them in a safe place.	3 Set aside time to listen as your teen tells you about each new teacher and each new class.	4 Your teen may need special supplies for school. Make plans to get them early in the year.	5 Kids who take part in extracurricular activities do better in school. Is there an activity that interests your teen?
6 If there's no activity that interests your teen, find out how she can start a club or activity she would like.	7 Does your teen have a regular study schedule? Set aside time every day for schoolwork, reading or review.	8 Today is International Literacy Day. Make sure everyone in the family has a library card.	9 Set limits on how often your teen can go out with friends during the school week.	10 Help your teen think about things she could study if she has only 10 minutes. Those little bits of time add up.	11 Does your teen have a learning disability? Have him ask teachers if he can sit in front so he has fewer distractions.	12 Buy a big calendar. Have your teen write down major projects and tests. This avoids last-minute panic.
13 Challenge your teen to get fit. Set up a fitness plan that includes some things you do together.	14 Many high schools sell calendars with events listed. Buy a copy and plan to attend an event this month.	15 When was the last time you told your teen you love him? Tell him today.	16 Find out when your high school has a Back-to-School Night. Be sure to attend.	17 Today is Citizenship Day. What does being a "good citizen" mean in your family? In school?	18 Is study time before dinner? Be sure to have healthy snacks on hand. Hungry teens can't concentrate.	19 Take your teen out for breakfast. Make this a monthly tradition.
20 Car crashes are the largest cause of teen deaths. Make sure your teen buckles up.	21 Go to the library. Explore the nonfiction section—learn more about a subject that interests your teen.	22 What's the best way for your teen to prepare for college entrance tests? Turn off the TV and read.	23 Do you know what drugs teens use today? Ask your school counselor for information.	24 Encourage your teen to keep a to-do list. By writing it down, he is less likely to forget what he needs to do.	25 Ask your teen's opinion of an idea or problem you have. Really listen to her answer.	26 Is your home "teen friendly"? Ask your teen what you could do to make it a place where friends would come.
27 Teens aren't too old for reading aloud. Start reading a favorite book aloud tonight.	28 Is your teen a reluctant reader? Ask the librarian to suggest a book that ties in with a popular movie.	29 Teens usually need more sleep than they get. Set a regular bedtime. Encourage your teen to take "power naps."	30 Only 37 percent of teens exercise regularly—but 35 percent watch at least three hours of TV daily. Get your teen active.	<h1>September 2009</h1>		

© 2009 The Parent Institute®, a division of NIS, Inc. May be reproduced only as licensed by *Parents Still make the difference!*® High School Edition newsletter. 1-800-756-5525

Parent Pointers

Calendar

Sunday	Monday	Tuesday	Wednesday	Thursday	Friday	Saturday
<h1>October 2009</h1>				1 Arguments with teens are inevitable. You don't always need the last word—don't get into a power struggle.	2 Look for ways to give your teen more responsibility: getting her doctor's appointments, etc.	3 Encourage your teen to spend 10 minutes at night getting ready for the next day to make mornings easier.
4 Watch a TV show with your child. Discuss how it does and does not reflect your family's moral values.	5 Help your teen make the connection between rights and responsibilities. Rights come with responsibilities attached.	6 Whether your teen is a freshman or a senior, she should be using the career planning services at school.	7 Do you have email? Use it to write your teen. You may say things you'd never say in person.	8 Would your teen like to earn money? (Most teenagers would.) Perhaps he can start his own small business.	9 Make tonight Kids' Night in the Kitchen. Your teen will learn to cook, communicate and cooperate!	10 Talk about school-related fears. Is your teen worried about bullies? Does he feel safe at school?
11 Model respect in your family. Don't tolerate name-calling, put-downs or insults from any family member.	12 Go to the library. Check out a best seller you and your teen can both read and then discuss.	13 No homework tonight? Have your teen review or read ahead. Daily study time means just that.	14 Challenge family members to learn two or three new vocabulary words each week.	15 Is your teen planning on going to college? Get a schedule of college entrance exams from the counselor.	16 Discuss the dangers of marijuana with your teen. It limits the brain's ability to absorb and retain information.	17 Is your teen's room messy? Set the timer for a 15-minute pick-up blitz before she goes out with friends.
18 It's Hunger Awareness Month. Do something to relieve hunger in your town or in the world.	19 If your teen makes a mistake, separate the deed from the doer. The choice was bad, not your child.	20 Teens tell you as much through behavior as through words. Make a special effort to "listen" to body language.	21 Teens don't always know how to say <i>no</i> . Role-play different situations where your teen should say <i>no</i> .	22 Have your teen keep a notebook when reading to jot down words she doesn't know and can look up later.	23 Big test coming up? Make a list of possible questions (and answers). It's a good way to review.	24 Discuss the conditions that are best for doing homework. Learning how your teen learns will help her succeed.
25 Have a "Family Night In." Pop some popcorn. Curl up with a book, a video or a game. Enjoy being together.	26 Go to the library. Have your teen check out information on colleges and other educational opportunities.	27 It's the birthday of Theodore Roosevelt. Talk with your teen about how you could take care of the environment.	28 Learn to see good and bad points in an argument. Have your teen respond as she thinks you would.	29 Tonight, attach a note to your child's pillow that tells her you love her.	30 Talk about what makes a good friendship with your teen.	31 Take your teen out for breakfast. No agenda—just talk.

© 2009 The Parent Institute®, a division of NIS, Inc. May be reproduced only as licensed by *Parents Still make the difference!*® High School Edition newsletter. 1-800-756-5525

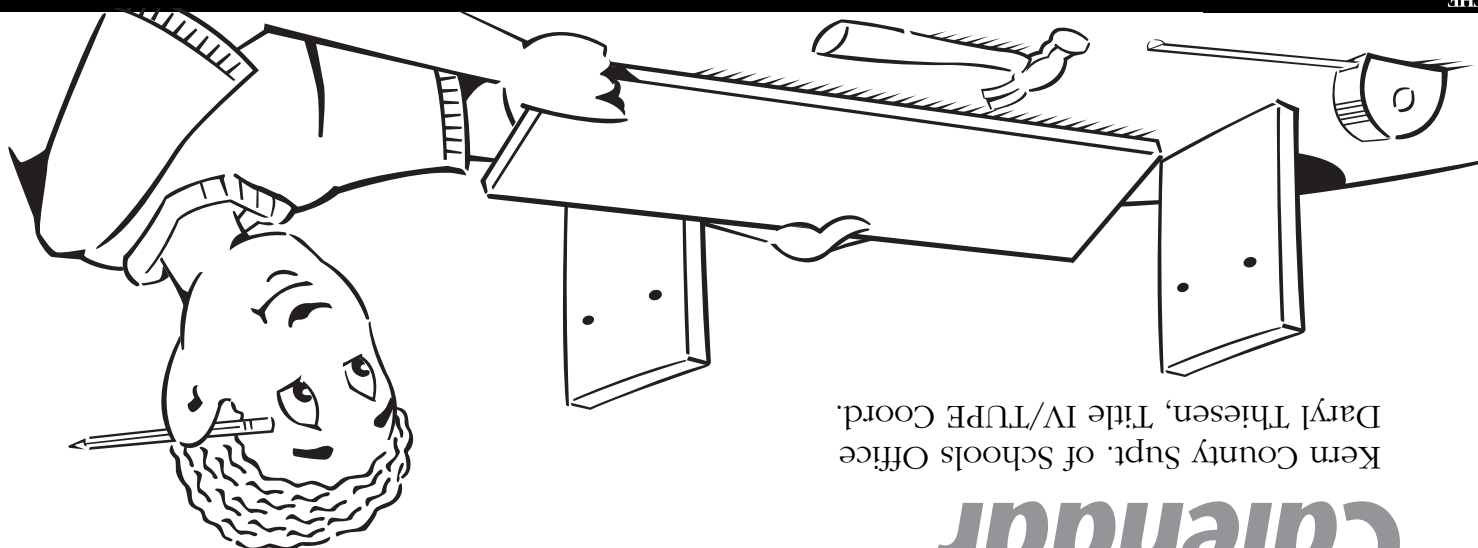

Kern County Supr. of Schools Office
Daryl Thiesen, Title IV/TUPE Coord.

Calendar

Parent Pointers

High School

Parent Pointers

Calendar



Sunday	Monday	Tuesday	Wednesday	Thursday	Friday	Saturday
1 This month, make plans to attend a community or school board meeting with your teen.	2 Help your teen draw up a résumé, even if she's young. List awards, jobs and volunteer service.	3 Have your teen research how and when he can register to vote.	4 Do your "homework" alongside your teen—pay bills, write letters or read.	5 Don't wait for your teen to raise the subject of AIDS. Look for a TV show or news story to open the topic.	6 Is your teen a visual learner? Have her make posters or flash cards to help with memorizing.	7 Is your teen an auditory learner? Have him tape record key ideas, then listen to them as he studies.
8 Look for a new skill or hobby to learn with your teen. It's a great way to get to know your teen on a new level.	9 One night this week, sit down and watch your teen's favorite TV show with her. Then talk about it afterward.	10 Before engaging in conflict, ask, "Is this really an issue that is worth a major battle? Or is compromise possible?"	11 Help your teen set priorities. Homework and chores come before work, TV and spending time with friends.	12 It's the birthday of suffragist Elizabeth Cady Stanton. Talk about how women's roles are changing.	13 Lots of homework? Your teen should tackle the toughest assignment first.	14 If your teen doesn't already do his own laundry, teach him.
15 Look for a volunteer activity you can do as a family.	16 This is American Education Week. Try to visit your teen's school this week.	17 It's Geography Awareness Week. Quiz each other on state, province and world capitals at dinner tonight.	18 When you're at the library, get the URL of the library's home page. Encourage your teen to check it out.	19 Ask to see your teen's homework. Talk about the useful knowledge she is acquiring for life.	20 Have your teen practice estimation. How long to finish this assignment? How far can I go on a tank of gas?	21 Cut out an article or comic strip your teen will enjoy. Leave it by her place at breakfast.
22 Give your teen a camera and ask her to record "A day in the life of our family."	23 If your teen comes home with a bad report card, try not to get angry. Instead, help him set clear goals.	24 Does your teen want a car? Have him do a cost analysis. Be sure to include insurance and maintenance.	25 Let your teen study with two colors of highlighters. One for important principles, the other specific facts.	26 Make it a "No TV" night tonight. Read as a family instead.	27 Is there a college nearby? Make plans to visit it with your teen.	28 Most teens have their first drinks at home. If you use alcohol, lock it up when you aren't around.
29 Invite your teen to bring a friend along to the movies, and allow them to sit separately. Discuss it afterwards.	30 It's Mark Twain's birthday. Check out one of his books. Take turns reading it aloud with your teen.	November 2009				